

Instructions

Gryphon Diamond Wire Saw *model Omni-2 Plus* +

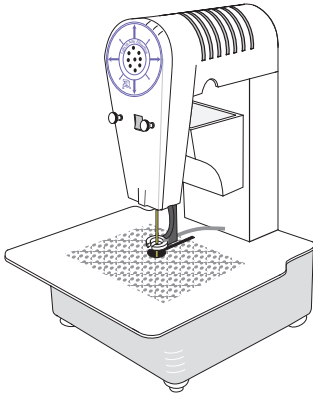

- Always wear eye protection •
- Do not run blade dry- use plenty of water •
- Keep fingers clear of moving parts •
- Do not operate with finger guard removed •
- Do not operate with front cover removed •
- Unplug saw when changing blades or guides •

Important - Fill Base completely with water before use

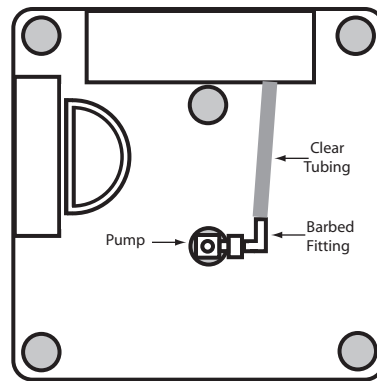
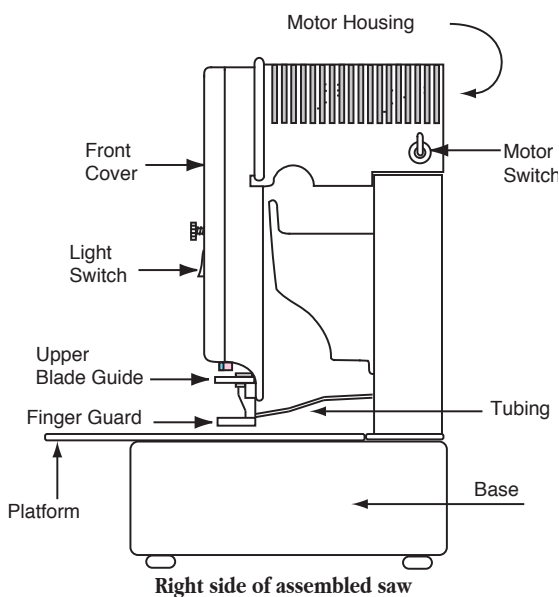

Base of saw viewed from above

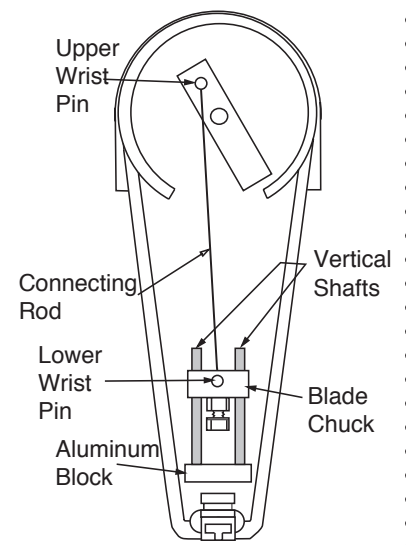

Upper Housing with Cover removed

Gryphon Wire Saw Parts Identification

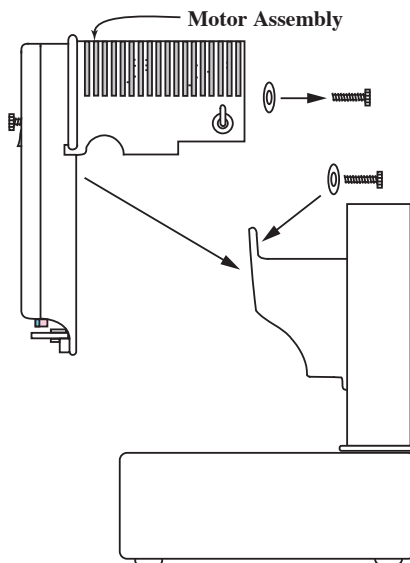

Assembly Step 1

Place motor assembly on top of base. Slip a plastic washer onto each of the two plastic thumbscrews found in your parts bag. Insert thumbscrews into blue vibration grommets at the upper outside corners of the housing. Tighten screws into motor assembly snug tight only (do not overtighten in order to minimize vibration).

Assembly Step 2 - Installing the Finger Guard and Tubing

Take the finger guard from your parts bag and push it into the "T" shaped slot at the bottom of the motor assembly.

Push the upper end of the tubing through the hole in the Finger Guard. The end of the tubing will touch the blade once you have installed the blade. To facilitate installing the tubing, you may want to apply a little lubricant (Vaseline, etc.) to the end of the tubing.

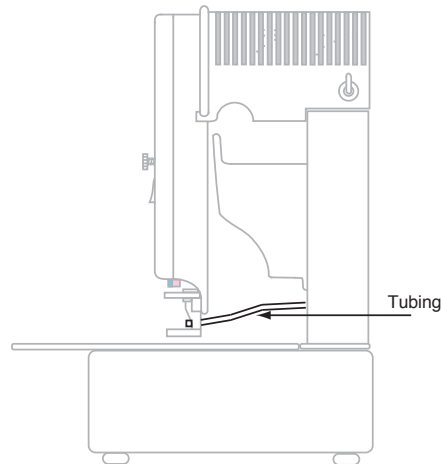
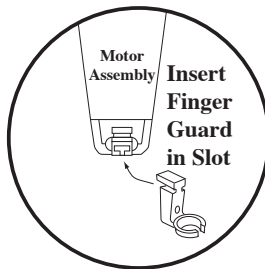

Assembly Step 3 - Installing your first blade

Note that you saw includes both Standard and Fine blades. We recommend that you start by using the Standard blade, as it is a good all-around choice. The Fine blade is useful for especially delicate glass, such as dichroic.

Remove the two nylon screws from the Front Cover and lift off the Front Cover.

The Rotor may stop in any position (A). Turn the Rotor by hand until the Blade Chuck is in its lowest position (B). (Note: for safety, always unplug the saw when changing blades, guides and other parts).

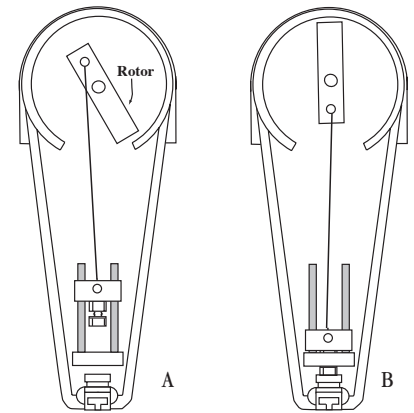

Insert the bottom guide by snapping it into the holder (the bottom guide is the one without the slot in the front). Drop the unpainted end of a new blade through the bottom guide hole and into the top of the pump (C).

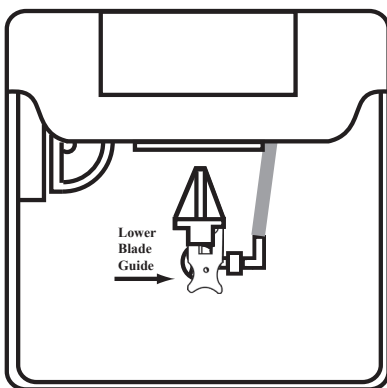

Snap the top painted end of the blade into the slot in the top guide. Push the blade up into the blade chuck until it stops (D). Tighten the 7/16" nut snugly with the provided wrench. To remove a worn blade reverse this process.

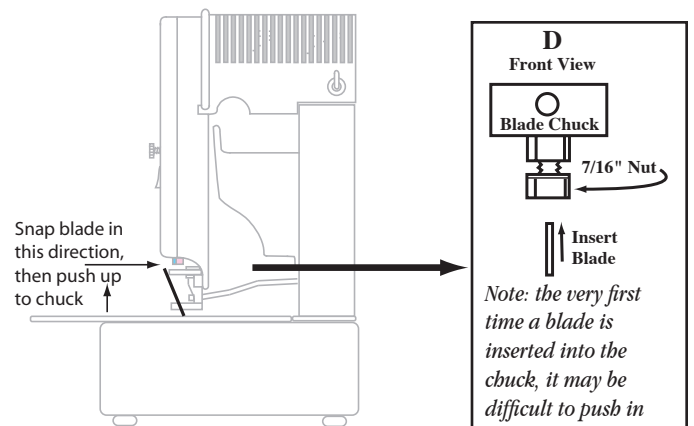

Note: the very first time a blade is inserted into the chuck, it may be difficult to push in the blade fully. Start by removing the nut entirely and inserting and removing the blade several times to loosen the grip of the Chuck. You want to insert the Blade into the Chuck to the point where 75% of the red paint on the blade is inside the Chuck. When you install the nut, do not overtighten. You should not tighten the nut to the point that the threads on the Chuck extend past the nut.

Assembly Step 4 - Installing batteries

Turn the Front Cover face down. Remove the four screws that secure the Battery Holder Lid. Lift off the Battery Holder Lid.

Install two AA flashlight batteries (not included) into the battery holder. Be careful to follow the polarity shown on the battery holder. Turn the switch on. If the lamp does not light, one or both of your batteries may be installed backwards.

Re-install the Battery Holder Lid. Start screws by twisting counter-clockwise until you feel the threads drop into place. Then twist the screws clockwise until they are snug tight. Over tightening will strip the treads. Never operate the saw with the Battery Holder Lid removed, as the batteries may fall into the mechanism.

Re-install the Front Cover and tighten the two plastic screws which you removed earlier.

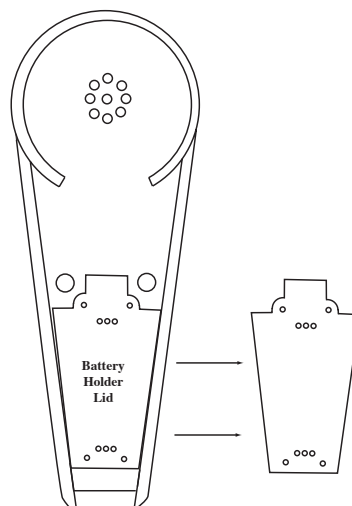

Preparing to Saw

Important: Fill the base with water to a level that covers the lower guide . The water provides cooling for the blade and extends guide life.

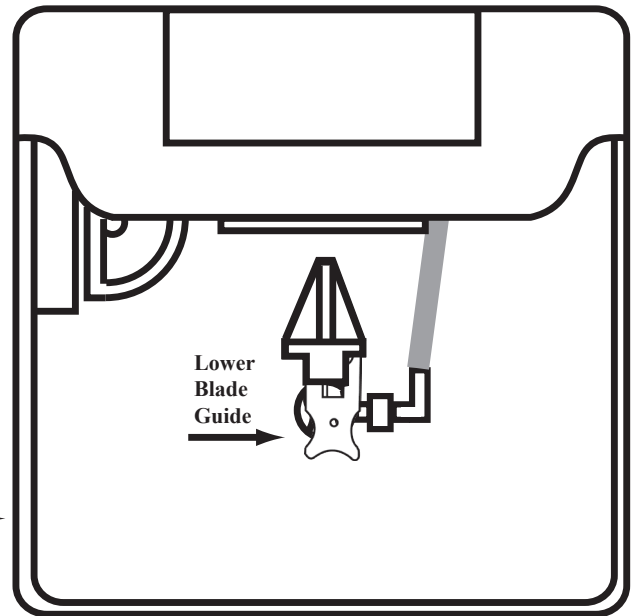

Wear eye protection. Turn the switch on and observe that the pump is supplying water to the blade. If no water is observed, turn off the saw, disconnect the tubing at the pump and blow the water out of the tube from the bottom end. Reconnect the tubing, turn the saw on and water flow should be restored. Once the blade has good water flow, you may begin sawing. You may push the glass in any direction.

It is a good idea to empty and clean the base every now and then to remove the glass sludge.

Fill the water tray with water to level indicated

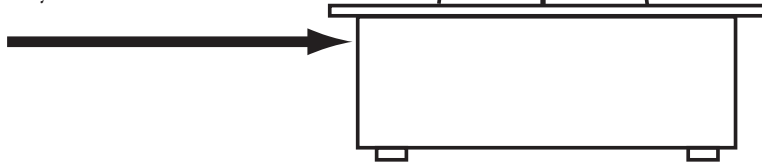

Water flow is automatic when the saw is running. Occasionally, air bubbles in the line may prevent proper flow, requiring that the line be blown free of bubbles as described at left. You can also use any small suction device to draw water through the tube and remove the air bubbles.

Start up Maintenance

It is necessary to keep the two steel vertical shafts lubricated with light oil. If your shafts do not feel oily to the touch, wipe light motor oil (such as sewing machine oil or clock oil) on them with your fingers. DO NOT use 3-in-1 oil. DO NOT use vegetable oil. DO NOT use spray lubricants.

These shafts are ground to micro finish in order to make your blade chuck last a long time. If you allow your shafts to rust or become dry you will drastically reduce the blade chuck life.

Sawing

Put on eye protection. Turn on the saw to start the water flow to the blade. The water feed tubing should touch the blade. Saw in any direction.

As you near the end of your cut, ease off on the pressure you apply to the glass to minimize risk of glass breakage.

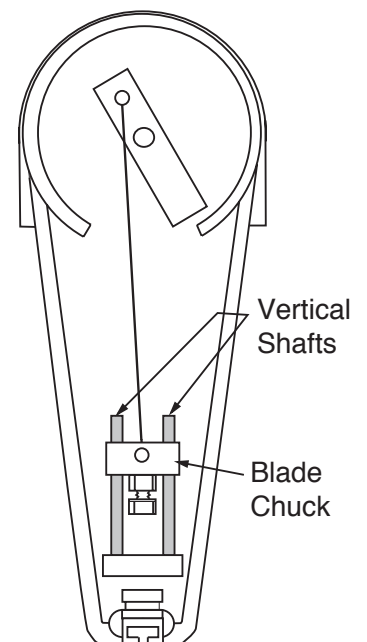

Stretching your \$\$\$\$

Most cuts will be done by pushing away from you and from side-to-side. This will dull the diamond on the blade front and sides, but leave the back relatively sharp. By loosening the Blade Chuck's 7/16" nut and turning the blade 180 degrees, you can extend your useful blade life. Note that the blade should never be installed upside-down. To do so will drastically shorten your guide and Blade Chuck life.

Just like a band saw, or any other diamond tool, these blades will become dull from use and you will have to push harder to make cuts. Pushing extremely hard can break your blade. Finally the blade will need to be replaced. The beauty of the Gryphon Wire Saw is that the blades are inexpensive. The Gryphon Omni-2 Plus+ Diamond Wire Saw is far more economical to use than any other glass saw.

Replacement blades - Gryphon Turbo Diamond Wire Blades

The **Fine Blade** is the finest grit, and offers the smoothest finish. It is recommended for dichroic or other delicate glass, and where the quality of the edge is important.

The **Standard Blade** is the most commonly used and is the best all-around blade choice. It offers excellent speed and long life.

The **Super Power Blade** offers the most aggressive cutting.

The **Slitting Blade** is thinner than the other blades, and is designed to cut front to back only. It is the fastest blade and removes the least material.

Changing parts

Blade Guides: Blade guides pull straight out toward the saw front. They snap in place, so expect a little resistance when removing and replacing them. Replace the guides when blade hole becomes sloppy. Note that the upper and lower blade guides are not interchangeable. The upper blade guide has a slot in the front.

Chuck: If the blade chuck wears from use the saw will become quite loud when running. To change:

1. Remove blade.
2. Loosen set screw in upper wrist pin.
3. Slide connecting rod out of upper wrist pin.
4. Pull connecting rod and blade chuck up and out of saw.
5. Loosen set screw in lower wrist pin and pull out connecting rod.
6. Put the wrist pin into a new blade chuck.
7. Push connecting rod into lower wrist pin hole until it stops, then tighten set screw with 5/64" Allen Wrench.
8. Replace assembly onto the two vertical shafts and thread connecting rod into the upper wrist pin.
9. Turn the rotor to down position as shown in the diagram to the right.
10. Insert the thin (gauge) end of your chuck wrench between the top of the aluminum block and the blade chuck. The wrench will create a 1/8" gap between the chuck and the aluminum block.
11. Push the blade chuck downward until the thin end of the chuck wrench is wedged snugly between the chuck and the aluminum block.
12. Tighten the set screw on the upper wrist pin and remove the chuck wrench. Oil both vertical shafts to complete the replacement.

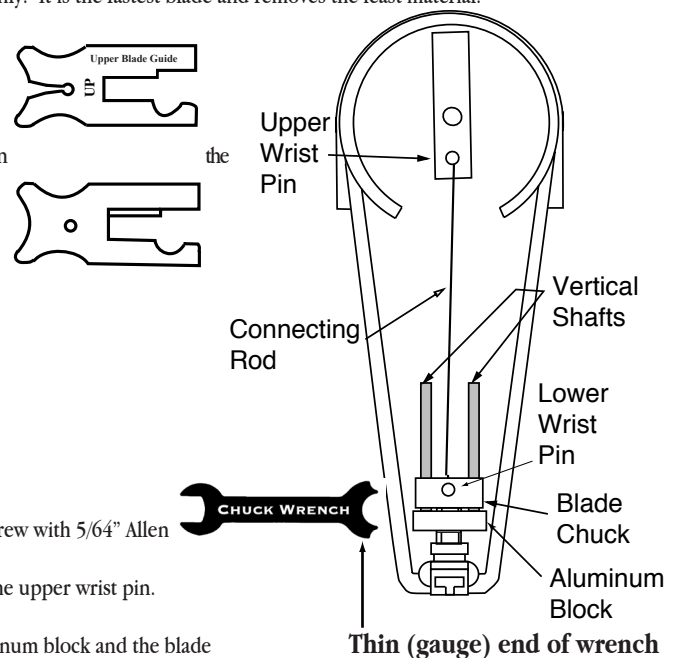

Pump: Unplug saw, remove old pump by disconnecting hose and pulling old pump straight up. Place new pump into white retaining ring in the recess in the base. Attach tubing coming from the tower to the barbed fitting on the pump.

Unclogging the water line

If you do not observe good water flow at the blade, turn off the saw, disconnect the tubing at the pump and blow the water out of the tube from the bottom end (blow the water towards the blade). Reconnect the tubing, turn the saw on and water flow should be restored.

For more information and hints, visit www.gryphoncorp.com/OmniFAQ.html

Warranty

- Your new Gryphon Diamond Wire Saw is warranted for five years from date of purchase. All mechanical parts with the exception of the normal wear parts (blades, blade guides, chuck and pump) are guaranteed against failure for five years. If such a failure occurs for any reason other than abuse or misuse during this period, it will be repaired (or at our option replaced) free of charge FOB our factory. Retain your sales receipt for proof of purchase. Should repairs ever be required, return the saw to Gryphon Corporation.